



(19) **United States**

(12) **Patent Application Publication**

**Matsuoka**

(10) **Pub. No.: US 2003/0011737 A1**

(43) **Pub. Date: Jan. 16, 2003**

(54) **METHOD FOR MANUFACTURING DISPLAY DEVICE**

**Publication Classification**

(51) **Int. Cl.<sup>7</sup> ..... G02F 1/1339**

(52) **U.S. Cl. .... 349/153**

(76) **Inventor: Hideki Matsuoka, Gifu-shi (JP)**

(57) **ABSTRACT**

Correspondence Address:  
**CANTOR COLBURN, LLP**  
**55 GRIFFIN ROAD SOUTH**  
**BLOOMFIELD, CT 06002**

A glass substrate of a display panel onto which an organic electroluminescence (EL) element or the like is formed is sealed by affixing the glass substrate and a sealing member such as a sealing glass onto which an adhesive has been applied. During this process, the temperature of the adhesive is controlled by, for example, controlling the temperature of the nitrogen gas to fill a chamber through a temperature adjusting device, so that the viscosity of the adhesive is adjusted. In this manner, quick and precise sealing of the display substrate by the sealing member and the adhesive can be achieved.

(21) **Appl. No.: 10/183,252**

(22) **Filed: Jun. 27, 2002**

(30) **Foreign Application Priority Data**

Jun. 29, 2001 (JP) ..... 2001-198921

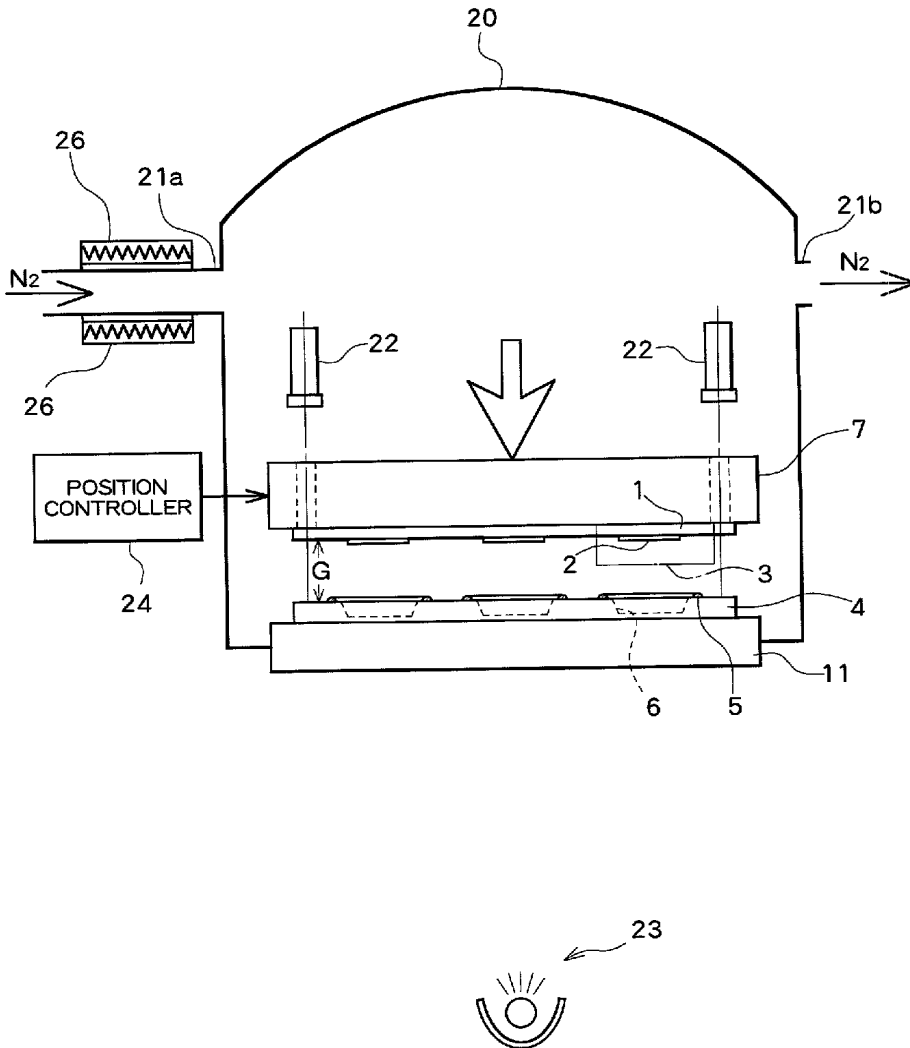

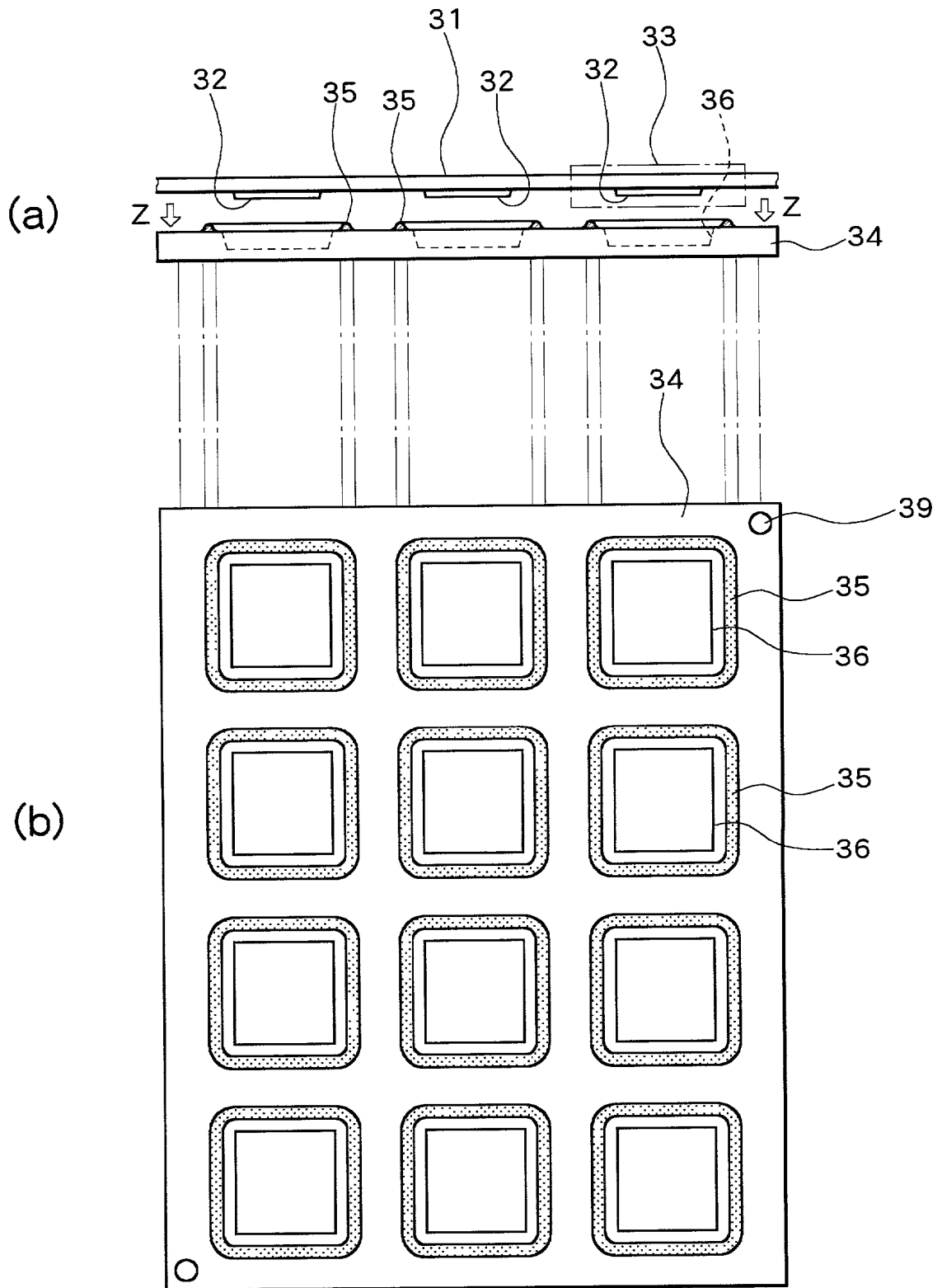

Fig. 1 RELATED ART

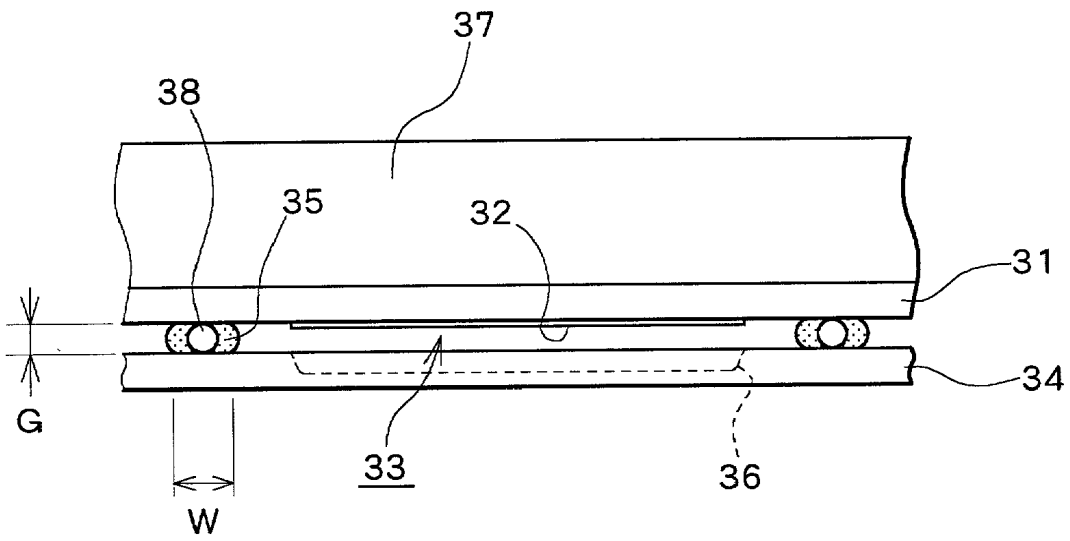

Fig. 2 RELATED ART

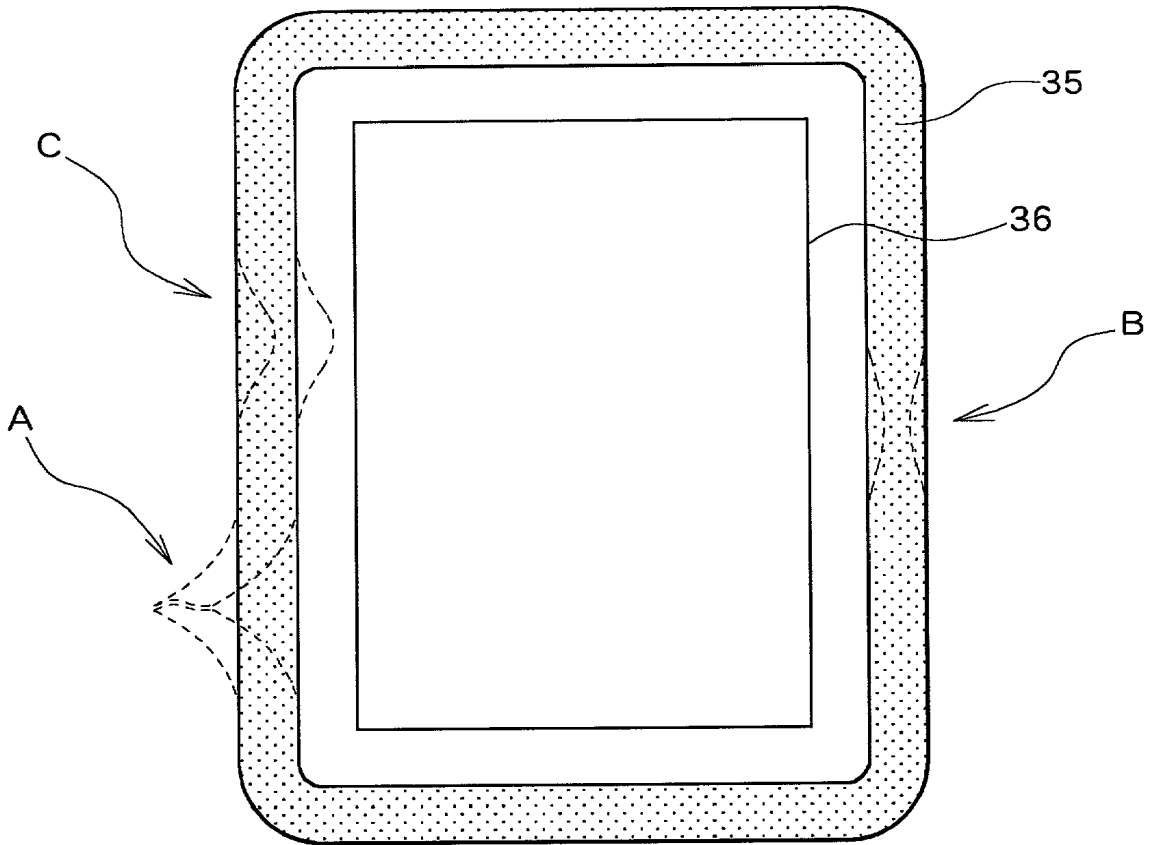

Fig. 3 RELATED ART

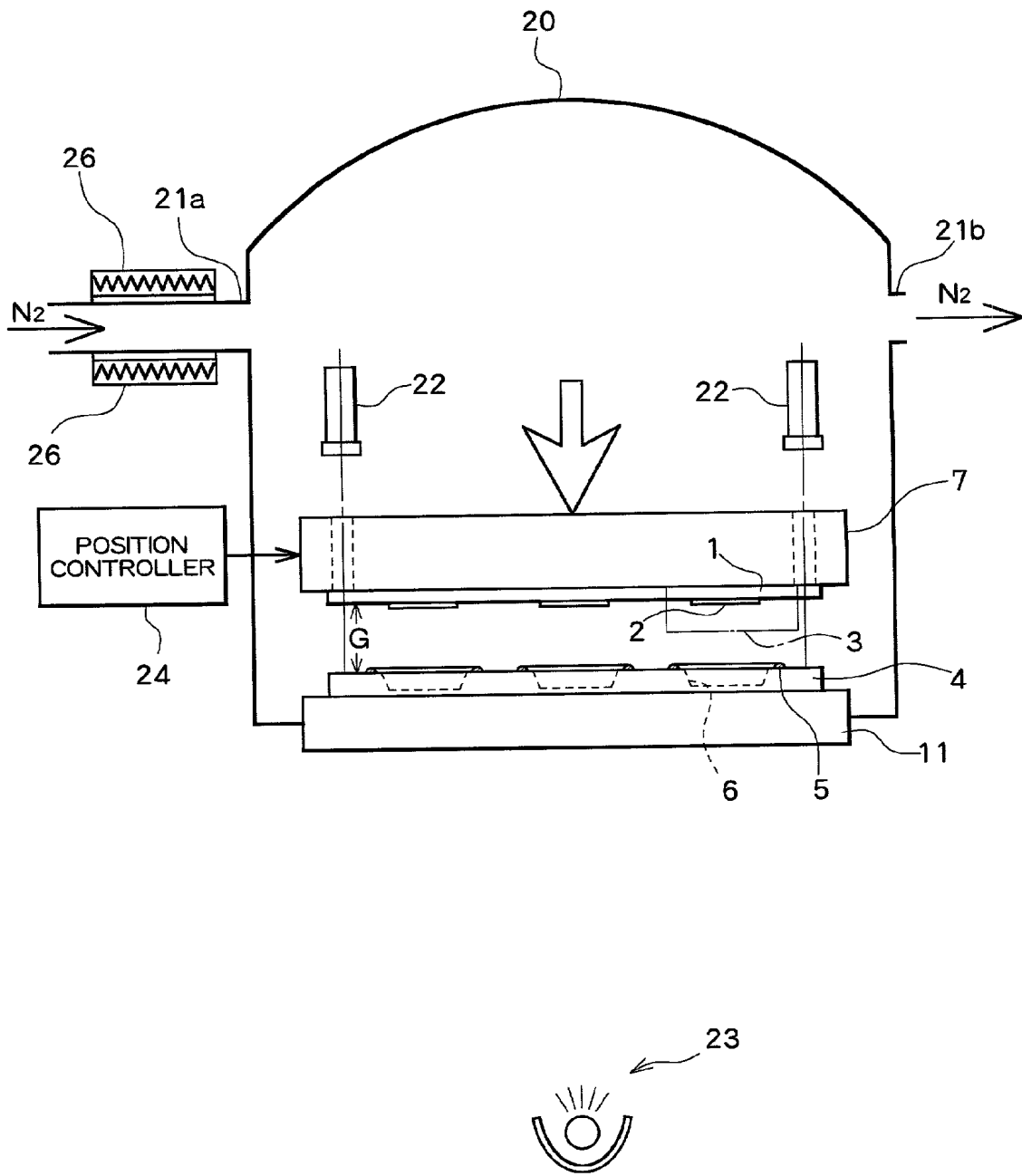

Fig. 4

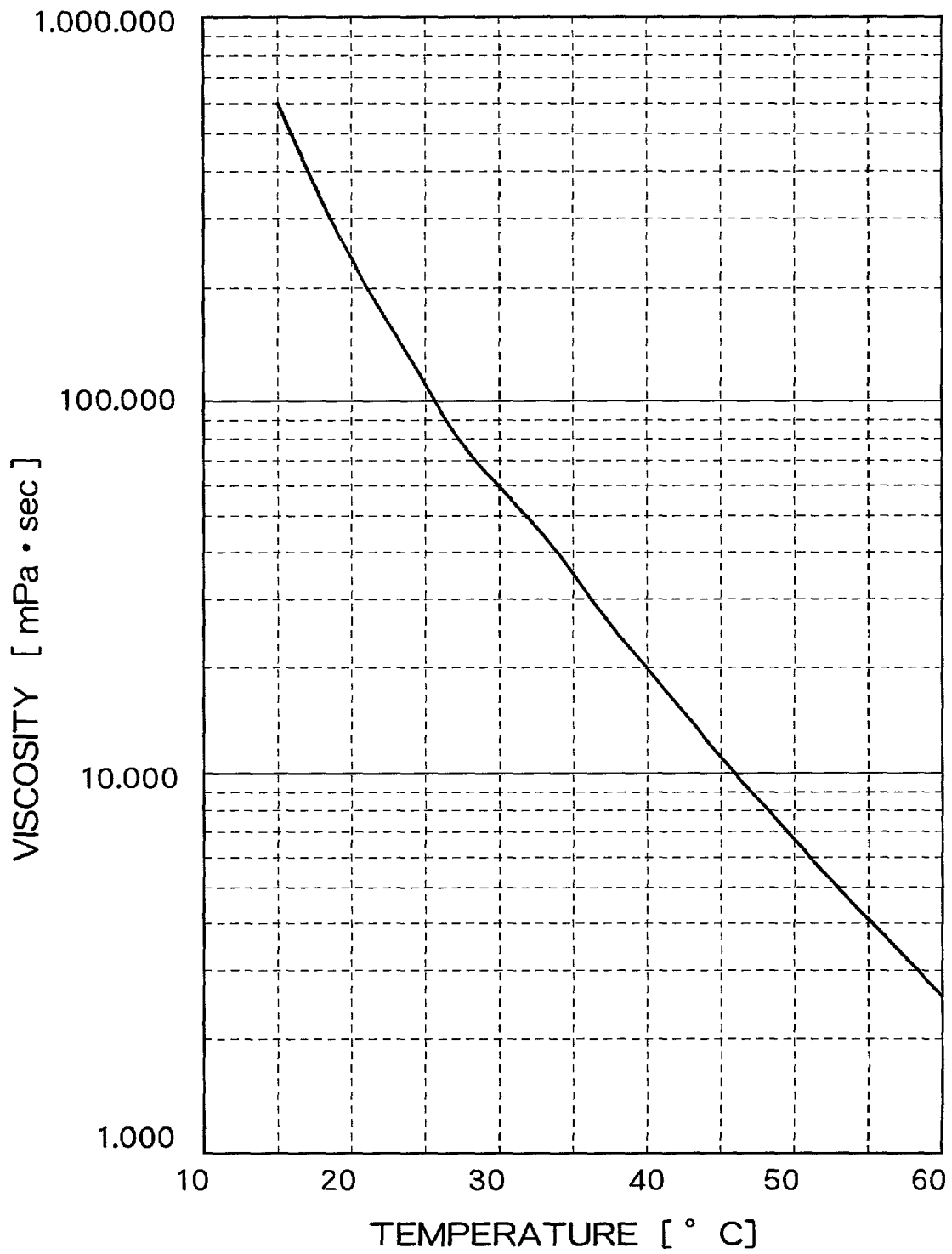

Fig. 5

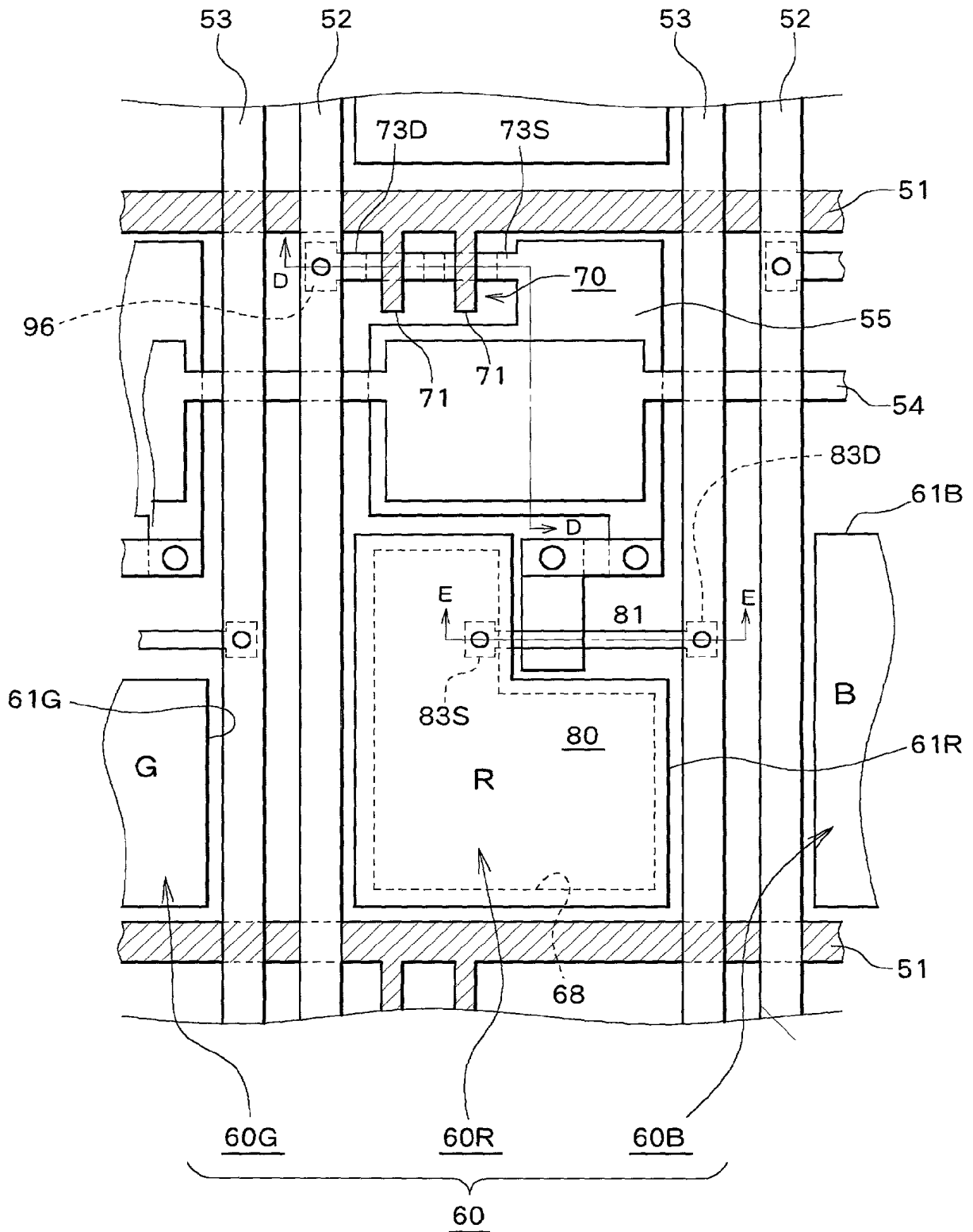

Fig. 6

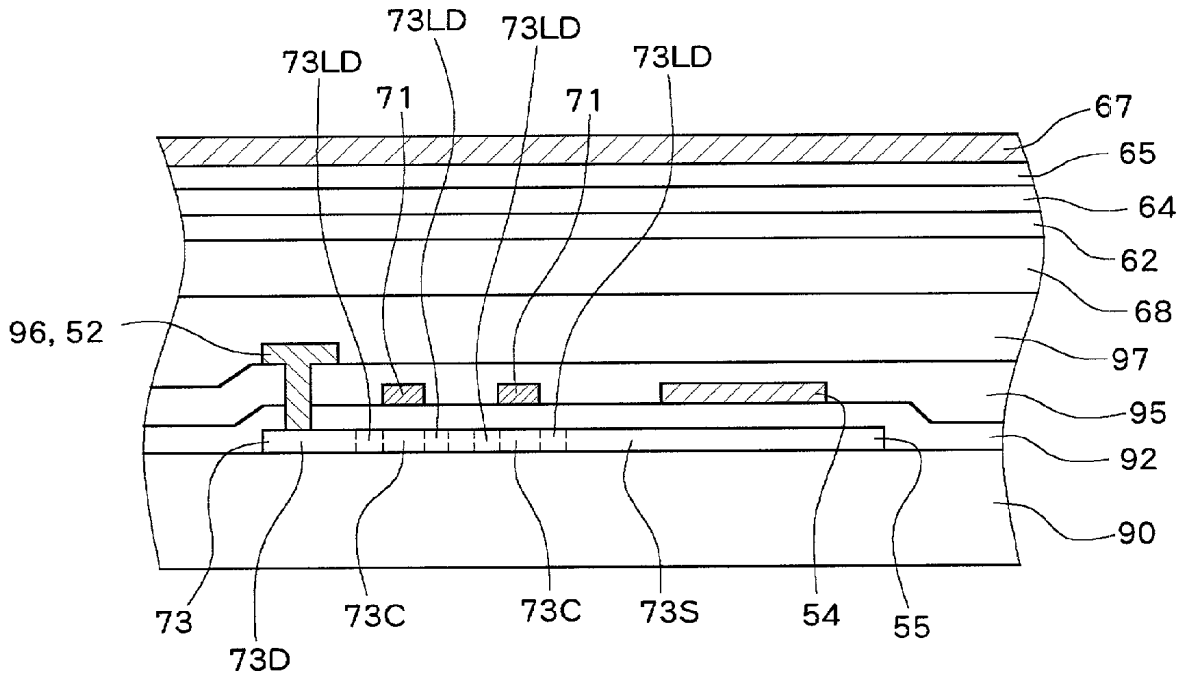

Fig. 7A

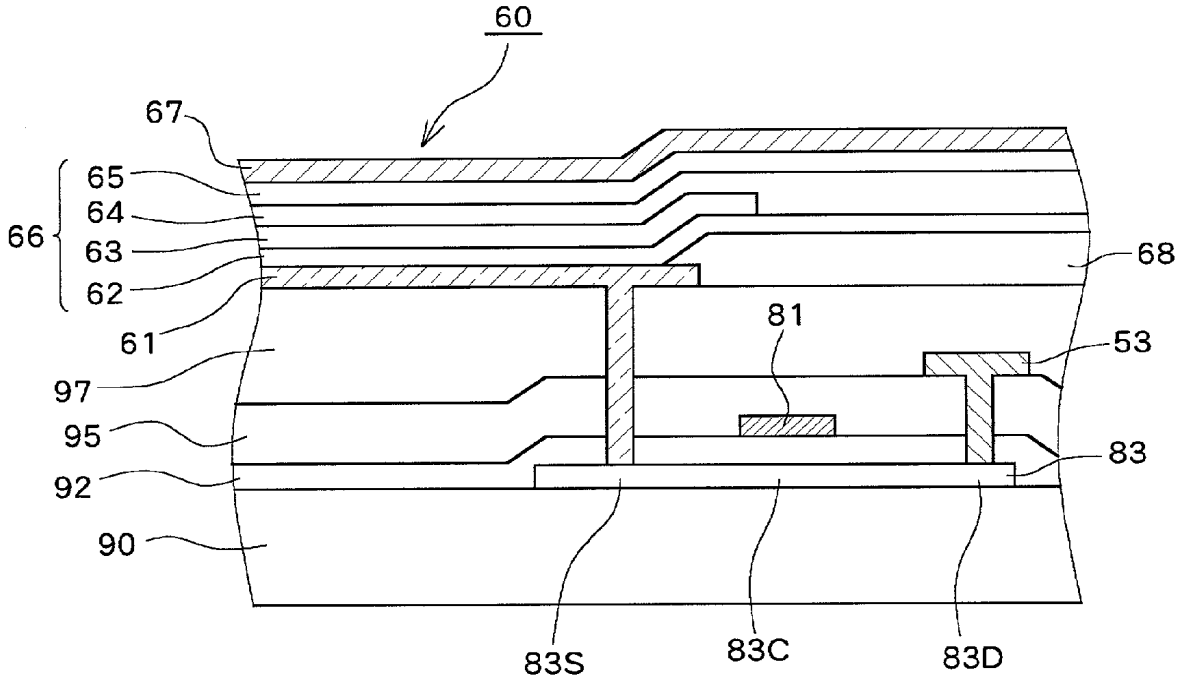

Fig. 7B

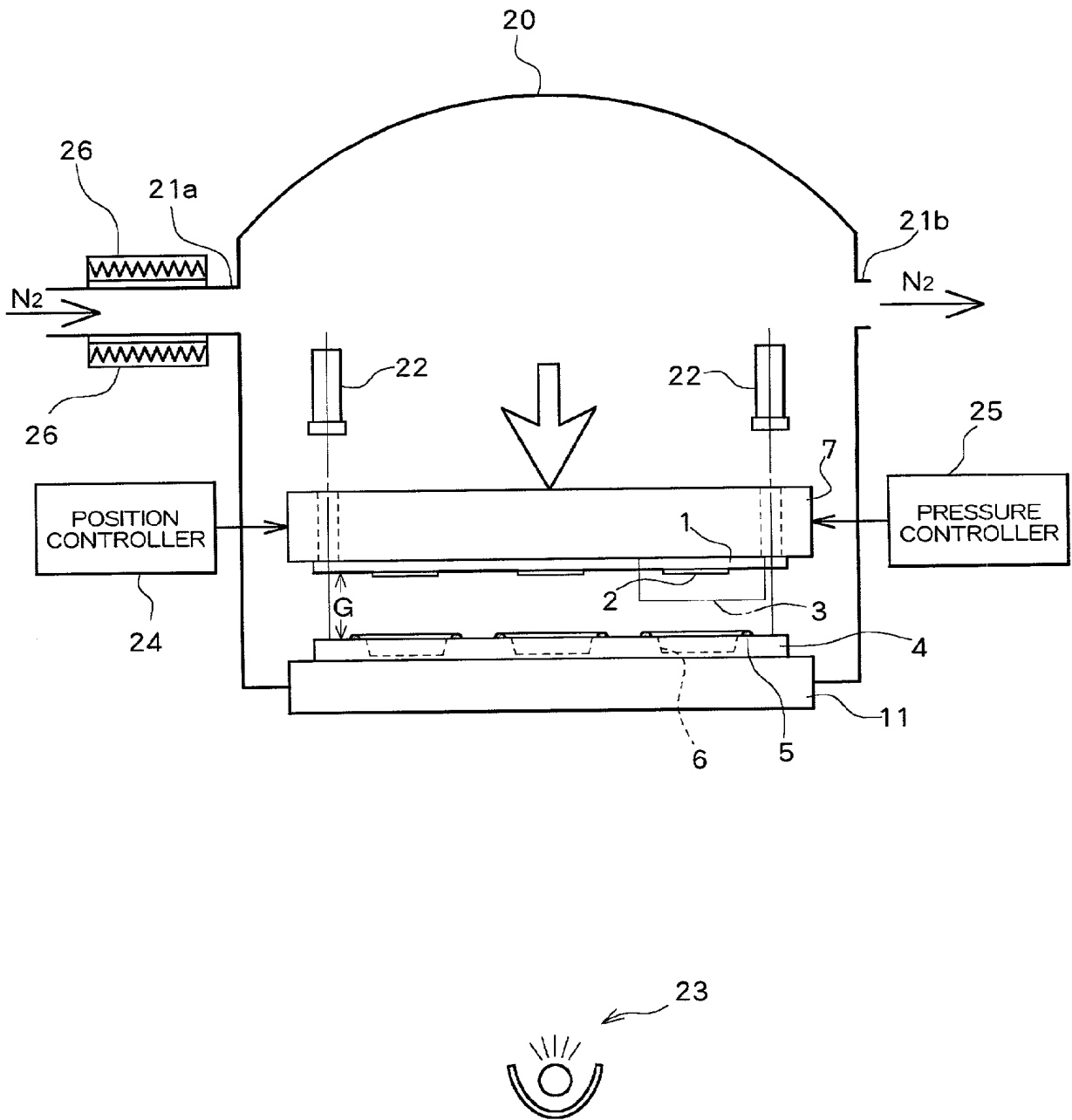

Fig. 8

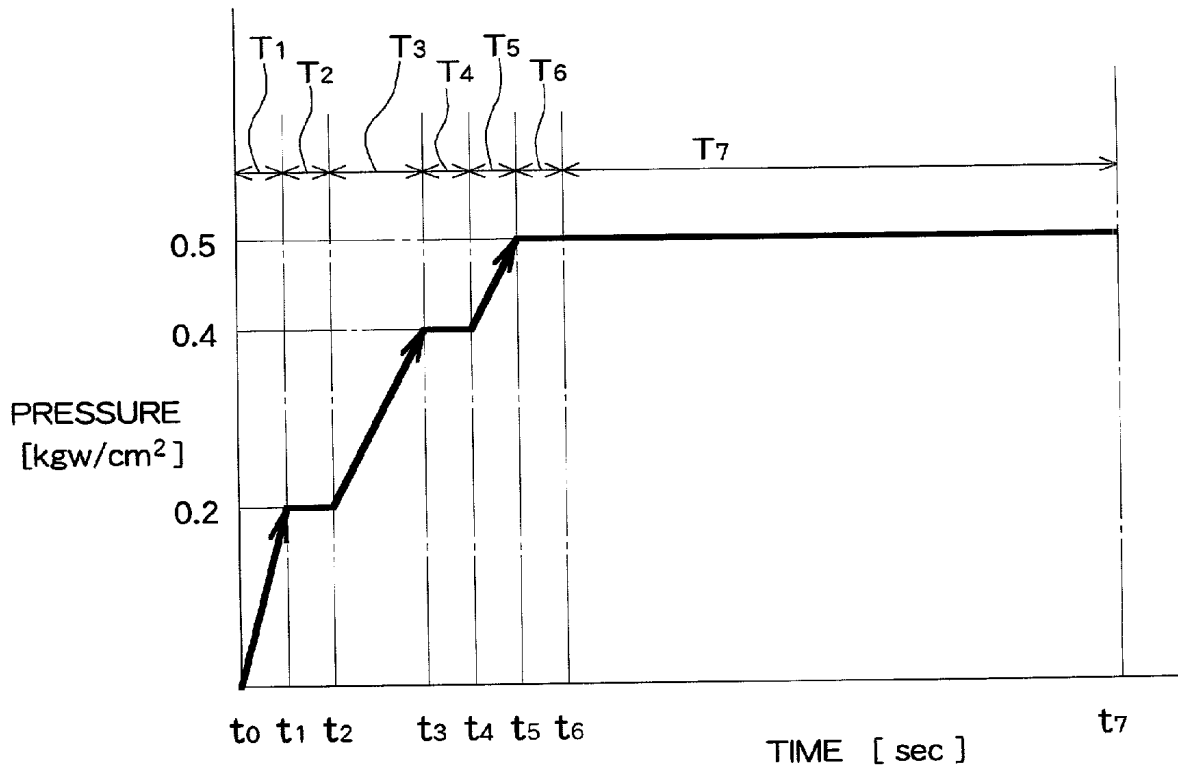

Fig. 9

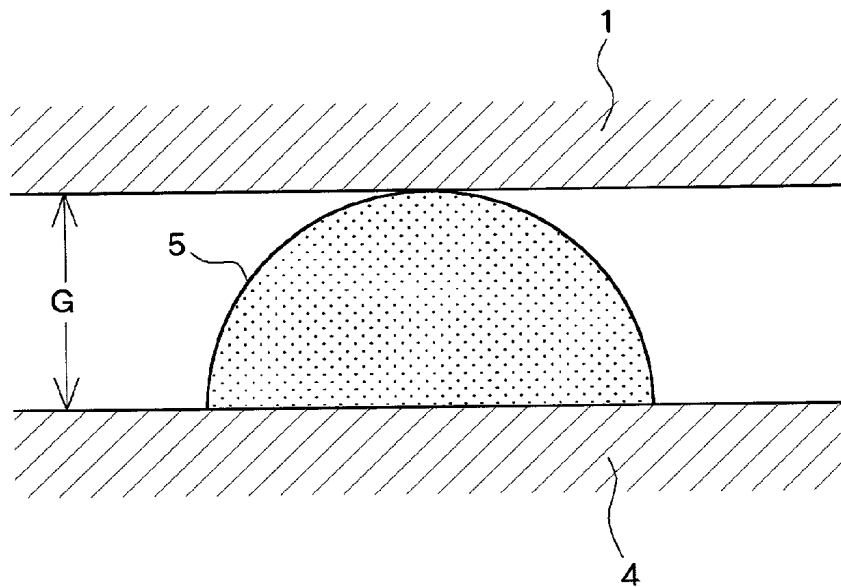

Fig. 10

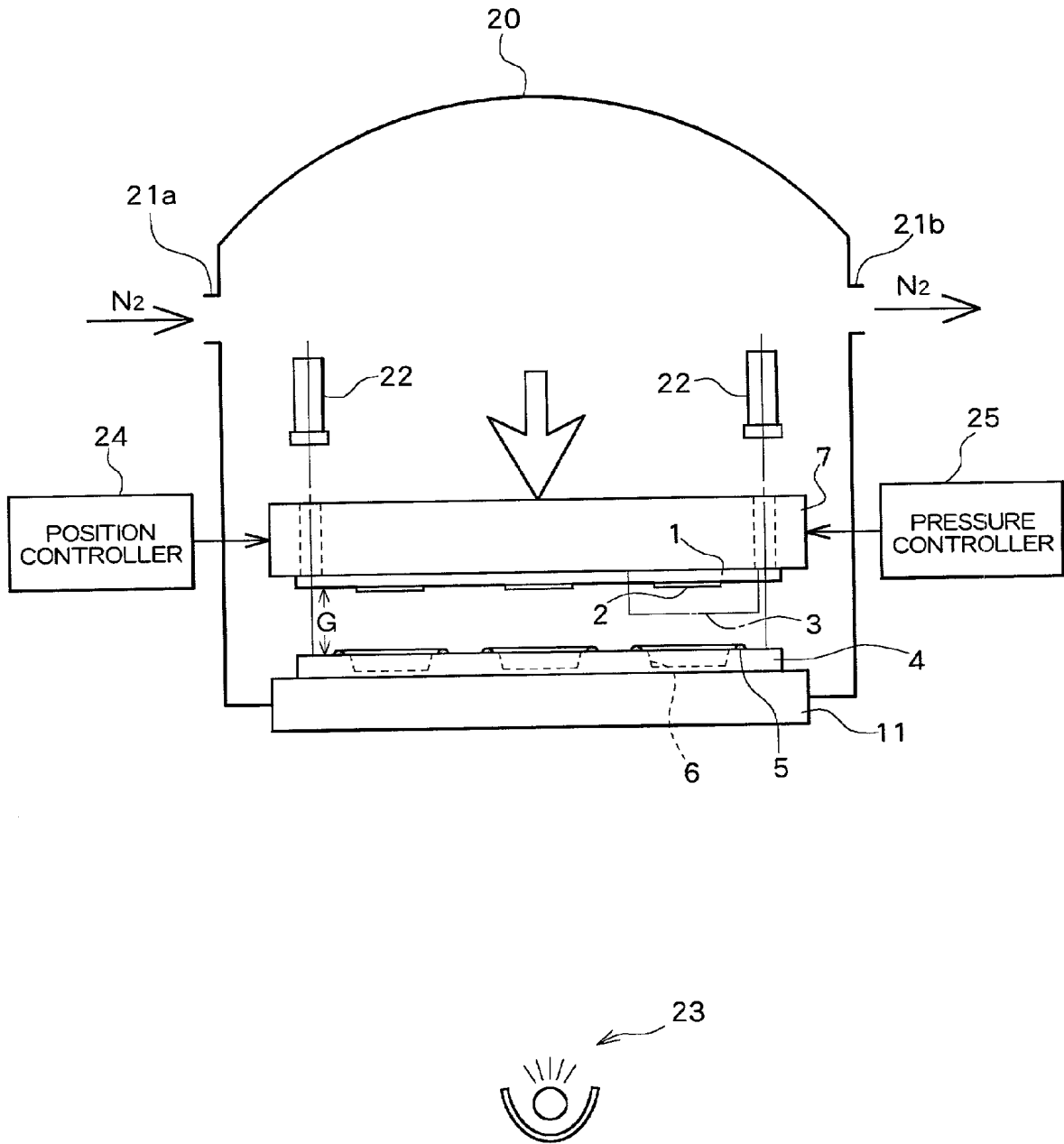

Fig. 11

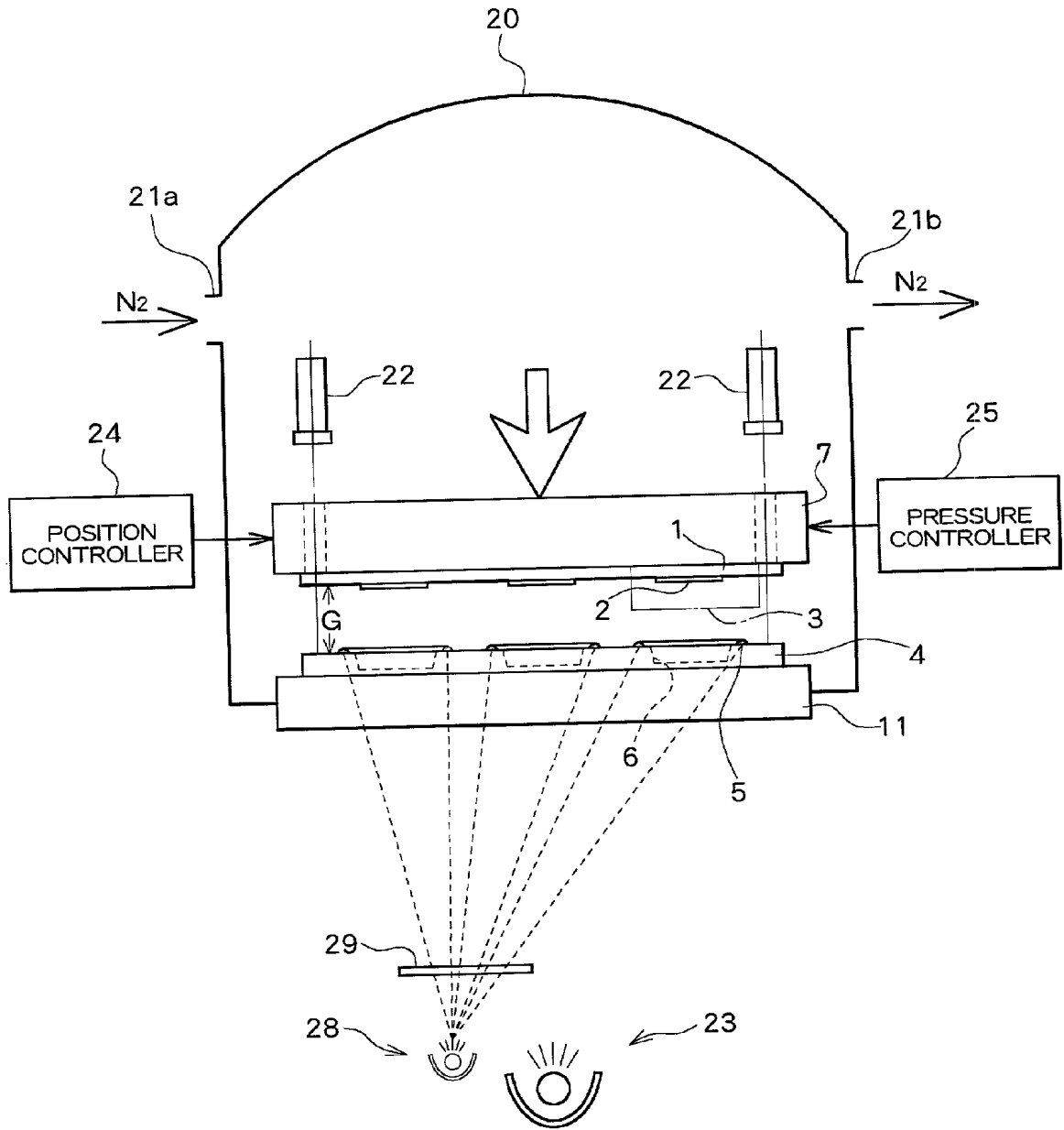

Fig. 12

## METHOD FOR MANUFACTURING DISPLAY DEVICE

### BACKGROUND OF THE INVENTION

#### [0001] 1. Field of the Invention

[0002] The present invention relates to a method for manufacturing a display device for displaying text, images, etc.

#### [0003] 2. Description of the Related Art

[0004] In general, display panels used in electroluminescence (EL) display devices and in liquid crystal display devices are constructed to include display substrates onto which display elements such as, for example, a light emitting element, liquid crystal, and a driving element for driving the light emitting element or liquid crystal are provided. Normally, in order to maintain the function and quality of the display substrate, the display substrate is sealed with a suitable sealing member. Examples of materials used for such a sealing member include metal and glass. The display substrate is affixed to the sealing member by an adhesive and sealed. The quality of sealing of the display substrate in the display panel is an important factor for determining the quality and lifetime of the display device.

[0005] FIG. 1 schematically shows how a display substrate is sealed by a sealing member.

[0006] As shown in FIGS. 1(a) and 1(b), element layers 32 which will become the display regions are formed through a thin film formation process on one side of a glass substrate 31 which is a type of display substrate 33. FIGS. 1(a) and 1(b) show an example configuration in which a plurality of (twelve) element layers 32 and a plurality of (twelve) display substrates 33 are simultaneously formed on a glass substrate 31 for simultaneously manufacturing a plurality of (twelve) display panels. The position of the glass substrate 31 relative to a sealing glass 34 which is the sealing member placed to oppose the element layers 32 is determined by an image processor or the like which recognizes one or more positioning marks 39 on the sealing glass 34. Then, the glass substrate 31 is moved in the Z direction shown in FIG. 1(a) and is affixed to the sealing glass 34. On the sealing glass 34, an adhesive 35 is applied in advance in a manner to surround the display regions along the shape to be sealed of the display substrates 33 (more specifically, their element layers 32). The surface of the sealing glass 34 opposing the display substrate 33 is engraved through etching or the like to correspond to the shapes and arrangement of the element layers 32. The engraved section 36 of the sealing glass 34 is provided for applying an absorbent or the like for maintaining the characteristics of the display substrate 33 to be sealed. In FIG. 1(b), the glass substrate 31 is not shown.

[0007] FIG. 2 schematically shows the cross section of the structure when the glass substrate 31 and the sealing glass 34 are affixed. The glass substrate 31 is held to a supporting member 37 using vacuum suction and affixed to the sealing glass 34 which is placed on a base (not shown). During this process, as shown in FIG. 2, the glass substrate 31 and the sealing glass 34 are pressed so that a predetermined gap G is formed between the glass substrate 31 and the sealing glass 34. After the gap G is adjusted to the predetermined value, a curing process for the adhesive 35 is applied and the display substrate 33 is sealed by the sealing glass 34. During

this sealing process, the width of the portion of the glass substrate 31 and of the sealing glass 34 in contact with the adhesive 35, that is, the seal line width W, is determined by the amount and viscosity of the adhesive 35, the gap G, the magnitude and duration of the applied pressure, etc. Also, a spacer 38 having a cylindrical or a spherical shape with a predetermined diameter, for example, is provided within the adhesive 35 (schematically shown in FIG. 2) so that a predetermined gap G can be obtained using the spacer 38 as a stopper for the pressure application.

[0008] Normally, a resinous adhesive is used as the adhesive 35. When a resinous adhesive is used, the material of the resin is selected based on the type of display substrate 33, the object of sealing, etc. However, for some of these resins, the viscosity cannot be adjusted.

[0009] For example, for a display substrate used in a display panel of an EL display device, that is, a display substrate 33 onto which an EL element is formed at the element layer 32, because an EL element has characteristics that its heat endurance is low and an EL element is easily degraded by moisture, an ultraviolet curable epoxy resin which has low permeability for water and, in addition, which does not require heating for curing is used as the adhesive 35. Because the ultraviolet curable epoxy resin is not diluted by any solvent, in general, the ultraviolet curable epoxy resin has a high viscosity and cannot be adjusted to a viscosity at which the resin can be easily used. In addition, if the viscosity is adjusted by changing the constitution of the ultraviolet curable epoxy resin, it is difficult to maintain the low water permeability characteristic of the resin.

[0010] When a resin having a high viscosity as described above is used as the adhesive 35, it is necessary, during the affixing of the glass substrate 31 and the sealing glass 34 as described above, to apply a higher pressure on the affixing surfaces of the substrate 31 and the sealing glass 34 to allow the gap G to reach a desired value and, at the same time, secure the seal line width W. However, if the magnitude of the applied pressure is rapidly increased, the adhesive 35 having a high viscosity cannot change its shape to respond to the change in the pressure, and affixing defects such as shown by dotted lines in FIG. 3 which is a plan view of the sealing glass 34 may be generated.

[0011] More specifically, when the adhesive 35 does not follow the change in the applied pressure and the gap G does not uniformly reach a desired value, defects such as (A) creation of a seal path through which the gas remaining in the inner space to be sealed can escape, (B) instability of the seal line width W, and (C) deviation of the adhesive 35 from the predetermined sealing position, may be generated. These are marked with the respective labels A, B, and C in FIG. 3. These affixing defects not only cause shape defects, but may also adversely affect the quality and lifetime of the EL display device by, for example, creating a sealing defect, causing the pressurized gas to remain inside, or increasing water permeability.

[0012] In addition to affecting the above described display substrate onto which an EL element is formed, the above-described disadvantages are common when sealing any display panel, such as, for example, a liquid crystal display substrate and a plasma display substrate, when the display substrate is sealed using a suitable sealing member and a highly viscous resin adhesive.

## SUMMARY OF THE INVENTION

[0013] The present invention was conceived to solve the above described problems and one object of the present invention is to quickly and precisely seal an element substrate with a sealing member and an adhesive.

[0014] In order to achieve at least this object, according to one aspect of the present invention, there is provided a method for manufacturing a display device in which an element substrate and a sealing substrate are affixed via an adhesive therebetween, wherein a display element is formed on the element substrate, the sealing substrate is placed to oppose the element substrate at the side onto which the display element is formed, and the adhesive is provided at positions to surround the formation region of the element; the element substrate and the sealing substrate affixed to each other are pressed; and the adhesive is cured; and wherein an ultraviolet curable resin is used as the adhesive; and the temperature of the adhesive is controlled before the adhesive is cured by irradiation of ultraviolet light.

[0015] According to another aspect of the present invention, it is preferable that, in the method for manufacturing, the adhesive is heated to a predetermined temperature before the element substrate and the sealing substrate affixed to each other via the adhesive there between are pressed. Or, alternatively, according to another aspect of the present invention, it is preferable that, in the method for manufacturing, the adhesive is heated to a predetermined temperature while the element substrate and the sealing substrate affixed to each other via the adhesive therebetween are pressed.

[0016] When, for example, a cation polymerizing, ultraviolet curable epoxy resin is used as the adhesive, by appropriately controlling the temperature of the adhesive, it is possible to appropriately control the viscosity of the resin or the like. In other words, even when an adhesive having a high viscosity at room temperature is employed, it is possible to control the viscosity by controlling the temperature. For example, by heating the adhesive to a predetermined temperature, the viscosity of the adhesive can be adjusted such that a desirable deformation rate of the adhesive can be realized when the substrates are affixed and pressed. Therefore, it is possible to quickly and precisely perform the operations for pressing the substrates, rolling the adhesive to a designated sealing width, and curing the adhesive.

[0017] In addition, by employing an ultraviolet curable epoxy resin as the adhesive, the resin can be cured by irradiation of ultraviolet light. Therefore, even when, for example, an organic electroluminescence element is employed as the display element, it is possible to prevent, during curing of the resin, exposure of the display element to a high temperature environment which may degrade the element characteristics, and thus a highly reliable display device can be obtained.

[0018] According to another aspect of the present invention, it is preferable that, in the method for manufacturing, the temperature of the adhesive is controlled based on application conditions of the pressure for pressing the element substrate and the sealing substrate.

[0019] When the affixed substrates are pressed, the adhesive provided between the substrates deforms at a rate based on the applied pressure and the viscosity of the adhesive at that point. Therefore, when the viscosity of the adhesive is

adjusted by controlling the temperature of the adhesive, it is possible to realize quick and reliable adhering of the substrates by the adhesive in consideration of the applied pressure.

[0020] According to another aspect of the present invention, it is preferable that, in the method for manufacturing, the pressure for pressing the element substrate and the sealing substrate is changed over time until a target gap is achieved between the element substrate and the sealing substrate affixed to each other. According to another aspect of the present invention, it is preferable that, in the method for manufacturing, the pressure for pressing the element substrate and the sealing substrate is changed over time by repeating a pressure changing period in which the pressure is changed and a pressure retaining period in which a constant pressure is maintained. According to another aspect of the present invention, it is preferable that, in the method for manufacturing, a plurality of the pressure changing periods and a plurality of the pressure retaining periods are repeated, and the duration of each of the plurality of pressure retaining periods is independently set to an arbitrary length. According to another aspect of the present invention, it is preferable that, in the method for manufacturing, a plurality of the pressure changing periods and a plurality of the pressure retaining periods are repeated, and the amount of change in pressure for each of the plurality of pressure changing periods is independently set to an arbitrary value.

[0021] According to another aspect of the present invention, it is preferable that, in the method for manufacturing, the pressure is changed over time through 3 repetition of pressure changing periods in which pressure is changed and pressure retaining periods in which a constant pressure is maintained.

[0022] In this manner, by changing the pressure for pressing the substrates over time based on various conditions, in addition to controlling the temperature of the adhesive, it is easy to obtain a uniform seal width and a uniform gap. In addition, by varying the applied pressure, it is possible to reliably deform the adhesive between the element substrate and sealing substrate by pressing, to easily control the deformation of the adhesive to be uniform at each position, and to obtain a uniform gap between the substrates and a uniform contact area (seal width) of the adhesive with respect to the affixing surfaces of the sealing substrate and the element substrate.

[0023] Moreover, as described above, by controlling the change over time of the applied pressure in stages, increasing the applied pressure in stages, or changing the applied pressure over time while monitoring the gap, precise and quick sealing process is facilitated.

[0024] Furthermore, the applied pressure can be changed, the pressure changing periods and pressure retaining periods can be repeated, and the conditions of each period can be set with a large degree of freedom in consideration of the characteristics of the adhesive or the like, allowing for smooth and uniform deformation of the adhesive provided between the substrates in response to the pressure for pressing the substrates. Therefore, quick sealing of the element substrate with the sealing substrate can be achieved while maintaining a superior quality.

[0025] Also, because a precise and quick sealing can be achieved through a simple controlling method of repeating

pressure changing periods and pressure retaining periods under suitable conditions, the method is significantly advantageous also in reducing the manufacturing cost.

[0026] According to another aspect of the present invention, it is preferable that, in the method for manufacturing, the amount of change in pressure for a final pressure changing period among the plurality of pressure changing periods is smaller than the amount of change in pressure for any of the previous pressure changing periods.

[0027] According to another aspect of the present invention, it is preferable that, in the method for manufacturing, the rate of change of pressure in at least one of the plurality of pressure changing periods differs from rates of change of pressure in the other periods.

[0028] For an adhesive having a relatively high viscosity, even when the temperature, for example, is controlled, the deformation rate in response to the pressure application is still reduced as the applied pressure is increased. Therefore, by setting the pressure changes so that the amount of change in pressure is smaller for a later period among a plurality of pressure changing periods, it is possible to uniformly deform such an adhesive while allowing reliable response to the applied pressure. Moreover, the deformation rate of the adhesive, that is, the inter-substrate gap can be controlled at a high precision with respect to the target inter-substrate gap, and thus, the sealing quality can be improved.

[0029] In addition, by making the pressure changing rate variable for each period, it is possible to uniformly and quickly deform the adhesive by pressing the substrates under optimal conditions based on the characteristics of the adhesive to be employed and to improve the sealing quality.

#### DESCRIPTION OF THE DRAWINGS

[0030] FIG. 1 is an explanatory diagram showing sealing, with a sealing glass, of a plurality of display substrates formed on a glass substrate according to a method for manufacturing a display panel of a related art.

[0031] FIG. 2 is an enlarged schematic cross sectional view of the glass substrate and the sealing glass affixed according to the related art.

[0032] FIG. 3 is a plan view showing example sealing defects in a method for manufacturing a display panel in the related art.

[0033] FIG. 4 is an explanatory diagram showing an example device structure for practicing a first embodiment of a method for manufacturing a display panel according to the present invention.

[0034] FIG. 5 is a graph showing a relationship between the temperature and viscosity of a cation polymerizing, ultraviolet curable epoxy resin which is used as an adhesive in the first embodiment of the present invention.

[0035] FIG. 6 is a plan view showing an example structure of an element layer of an organic EL display panel.

[0036] FIGS. 7A and 7B are cross sectional diagrams showing an example structure of an element layer of an organic EL display panel.

[0037] FIG. 8 is an explanatory diagram showing an example device structure for practicing a second embodiment of a method for manufacturing a display panel according to the present invention.

[0038] FIG. 9 is a time chart showing an example pattern for application of pressure for pressing the affixing surfaces between the display substrate and the sealing glass in the second embodiment according to the present invention.

[0039] FIG. 10 is a schematic cross sectional view for explaining deformation of the adhesive.

[0040] FIG. 11 is an explanatory diagram showing an example device structure for practicing an alternate configuration of a first or second embodiment according to the present invention.

[0041] FIG. 12 is an explanatory diagram showing an example device structure for practicing a further alternate configuration of a first or a second embodiment of the present invention.

#### DESCRIPTION OF PREFERRED EMBODIMENTS

[0042] (First Embodiment)

[0043] A first preferred embodiment of a method for manufacturing a display panel of a display device according to the present invention will now be described referring to FIGS. 4 and 5 using an example in which the method is used for manufacturing a display panel having a display substrate (element substrate) constructed to include an organic EL element as the display element. In the first embodiment, similar to the conventional art exemplified above and shown in FIGS. 1 and 2, for sealing, with a sealing member (in the embodiments, glass; hereinafter referred to as "sealing glass"), the display substrate constructed by forming an element layer on a glass substrate, an adhesive is applied in advance on the affixing surface between the sealing glass and the display substrate in a manner to surround the display regions of the display substrate. After the sealing glass and the display substrate are affixed, a pressure is applied to the affixing surface. Then, after the gap between the sealing glass and the display substrate has reached a target value, the adhesive is cured. The pressure to be applied may be constant, or, alternatively, may be changed over time as will be described below relative to other embodiments of the present invention.

[0044] FIG. 4 is a schematic diagram showing an example structure of an apparatus for manufacturing a display panel by the method for manufacturing according to the first embodiment.

[0045] As shown in FIG. 4, on one surface of glass substrates 1 which are a type of a display substrate 3, element layers 2 constructed from an organic EL element or the like are formed through a thin film formation process. Again, in this structure, similar to FIG. 1, for example, a plurality of element layers 2 are simultaneously formed on a glass substrate 1 (mother substrate) and a plurality of display substrates 3 are simultaneously created so that a plurality of display panels are manufactured simultaneously. The glass substrate 1 is affixed (adhered) to a sealing glass 4, which is a sealing member placed to oppose the element layers 2. On the sealing glass 4, an adhesive 5 is applied in a manner to surround the display substrate 3, that is, along the shape for sealing the element layers 2. The adhesive 5 is made of an ultraviolet curable resin having a high viscosity, for example, a cation polymerizing, ultraviolet curable epoxy resin. The cation polymerizing, ultraviolet curable

epoxy resin is well suited for an application to seal the organic EL element or the like because the resin has characteristics of low contraction ratio during curing process and low permeability for water. In addition, the surface of the sealing glass 4 which opposes the display substrate 3 is engraved through etching or the like to correspond to the shape and arrangement of the display substrates 3 (more specifically, their element layers 2). The engraved section 6 of the sealing glass 4 is provided for applying an absorbent or the like for maintaining the characteristics of the display substrate 3 to be sealed.

[0046] Each of the above described members is placed in a chamber 20. The inside of the chamber 20 is filled with nitrogen gas (N<sub>2</sub>) which is supplied to and discharged from the chamber 20 through a respective gas introduction port 21a and gas discharging port 21b. In order to prevent degradation of the organic EL element by the moisture present in the atmosphere, nitrogen gas having a moisture content of 5 ppm or less is used. Also, the temperature of nitrogen gas to fill the chamber 20 can be controlled by a temperature adjusting device 26 provided at the gas introduction port 21a. By controlling the temperature of nitrogen gas, it is possible to simultaneously control the temperature of the adhesive 5.

[0047] In the chamber 20, the glass substrate 1 is vacuum suctioned to a supporting member 7 provided within the chamber 20. The position of the supporting member 7 is controlled. In FIG. 4, the apparatus (mechanism) for vacuum suctioning the glass substrate 1 is not shown. On the other hand, the sealing glass 4 is placed on a quartz glass 11 which is installed at the bottom surface of the chamber 20. An apparatus 24 for controlling the position of the supporting member 7 moves the supporting member 7 and the glass substrate 1 in the horizontal direction based on an image of, for example, one or more positioning marks (not shown) which are imaged by one or more CCD cameras 22 provided within the chamber 20, and determines the relative position of the supporting member 7 and the glass substrate 1 with respect to the sealing glass 4. After the positioning process is completed, an apparatus for applying a pressure to the supporting member 7 (not shown) applies a pressure to the supporting member 7 and the glass substrate 1 in the direction shown by the arrow towards the sealing glass 4 so that pressure is applied at the affixing surfaces of the glass substrate 1 and the sealing glass 4. In the manufacturing apparatus shown in FIG. 4, the reference numeral 23 denotes an ultraviolet light source for irradiating ultraviolet radiation through the quartz glass 11 and the sealing glass 4 onto the adhesive 5 composed of the cation polymerizing, ultraviolet curable epoxy resin, for curing the adhesive 5.

[0048] Next, a method for manufacturing a display panel of an EL display device according to the first embodiment using such an apparatus will be described.

[0049] In the first embodiment, the sealing process is performed while controlling the temperature of the nitrogen gas. If the set temperature is too high, the characteristics of the organic EL element formed on the display substrate 3 are degraded and, moreover, the viscosity of the adhesive 5 may become too low such that the adhesive may flow away from the affixing surface. Because of this, in order to seal the display substrate 3 in a desired manner, it is preferable to set the temperature within the chamber 20, that is, the tempera-

ture of the nitrogen gas, in a suitable temperature range, taking into consideration the relationship with respect to the pressure to be applied.

[0050] FIG. 5 is a graph showing the relationship between the temperature and the viscosity of the adhesive 5 formed of a cation polymerizing, ultraviolet curable epoxy resin used in the first embodiment. It has been found that the viscosity of this adhesive 5 rapidly decreases as the temperature rises, as shown in FIG. 5. Normally, the standard temperature of the clean room in which the sealing process is performed is approximately 24° C. The temperature of the adhesive 5 is equal to this temperature of 24° C., and as shown in FIG. 5, the viscosity of the adhesive at this temperature is high and exceeds 100000 mPa·sec. This property of the adhesive constitutes a barrier to quick and accurate sealing of the display substrate.

[0051] In the first embodiment, the temperature of nitrogen gas filling the chamber 20 is set at 35° C. prior to the irradiation of the adhesive 5 with ultraviolet light. With this process, the temperature of the adhesive 5 is also set approximately at 35° C. As shown in FIG. 5, the viscosity of the adhesive 5 at this temperature of 35° C. is approximately 34000 mPa·sec which is one order of magnitude smaller than the viscosity at the standard temperature of the clean room, approximately 24° C. More importantly, at the temperature of 35° C., the characteristics of the organic EL element formed on the display substrate is not degraded by the heat.

[0052] In this manner, while the temperature of the adhesive 5 is maintained at approximately 35° C., the position controller 24 is operated based on one or more images obtained by one or more CCD cameras 22 to determine the horizontal position of the glass substrate 1 relative to the sealing glass 4. After the positioning process, the supporting member 7 which supports the glass substrate 1 is vertically lowered towards the sealing glass 4 and a pressure is applied to the affixing surface between the display substrate 3 and the sealing glass 4. Through this pressure, the adhesive 5 controlled to be at the set temperature as described above is desirably deformed and the gap G between the affixing surfaces can easily reach its target value. After the gap G has reached the target value, the ultraviolet light source 23 is switched on in order to irradiate ultraviolet light onto the adhesive 5 to cure the adhesive 5 and thereby seal the display substrate 3 with the sealing glass 4.

[0053] For reference, an example structure of an element layer 2 formed on the display substrate 3 which is used as the organic EL display panel will now be described.

[0054] FIG. 6 is an enlarged plan view of a pixel and its periphery of an active matrix type EL display panel in which a thin film transistor (TFT) which is an active element is added for each EL element forming a display unit (pixel) of the display device.

[0055] The EL display panel is a display device which takes advantage of the property of an EL element which emits light when an electric field is applied. On a display substrate, gate signal lines for driving switching TFTs and signal lines for allowing display of each pixel are formed in rows and columns in a matrix form.

[0056] As shown in FIG. 6, in the EL display panel, gate signal lines 51 and drain signal lines 52 are formed as the

signal lines as described above. Organic EL elements **60** are formed as pixels corresponding to the intersections of these signal lines. In the EL display panel, in order to realize a full-color display, repeating units are formed each consisting of three types of organic EL element **60R**, **60G**, and **60B** having different emission colors. These three types of EL elements form a group to constitute a display unit as a full-color display device for emitting light of a desired color.

[0057] In the vicinity of an intersection between the signal lines, a TFT **70** which is switched by the gate signal line **51** is formed. When the TFT **70** is switched "ON", the signal on the drain signal line (data signal line) **52** is connected to the source **73S** and applied to a capacitor electrode **55**. The capacitor electrode **55** is connected to a gate **81** of a TFT **80** for driving an EL element. The source **83S** of the TFT **80** is connected to an anode **61** of the organic EL element **60** and the drain **83D** of the TFT **80** is connected to the driving power supply line **53** which functions as an electric current source for supplying electric current to the organic EL element **60**.

[0058] Corresponding to the TFTs **70** and **80**, a storage capacitor electrode line **51** is formed parallel to the gate signal line **51**. The storage capacitor electrode line **54** is formed of, for example, a metal such as chromium (Cr), similar to the gate signal line **51**. The storage capacitor electrode line **54** and the capacitor electrode **55** which is placed to oppose the storage capacitor electrode line **54** with an insulative film in between constitute a capacitor element (storage capacitor) in which charges are accumulated. The storage capacitor is provided for maintaining the voltage applied to the gate electrode **81** of the TFT **80**.

[0059] FIGS. 7A and 7B show cross sections near the pixel shown in FIG. 6. FIG. 7A shows a cross section along the line D-D in FIG. 6 and FIG. 7B shows a cross section along the line E-E in FIG. 6. As shown in FIGS. 7A and 7B, the element layer of the display substrate in the organic EL display panel is formed by sequentially layering the TFT and the organic EL element **60** on substrate **90** such as a glass substrate, a synthesized resin substrate, a conductor substrate, or a semiconductor substrate.

[0060] The formation process of the TFT **70** for controlling the charging/discharging of the capacitor electrode **55** will first be described.

[0061] As shown in FIG. 7A, on an insulative substrate **90** made of quartz glass, non-alkali glass, or the like, an active layer **73** is formed which is made of a polycrystalline silicon film obtained by polycrystallizing an amorphous silicon film through irradiation of laser. In the active layer **73**, a structure commonly known as an LDD (Lightly Doped Drain) structure is created. More specifically, on both sides of the channel, low concentration regions **73LD** are provided, and further a source **73S** and a drain **73D** which are high concentration regions are provided outside the LD region **73LD**. Over the active layer **73**, a gate insulative film **92** and a gate electrode **71** which constitute a portion of the gate signal line **51** made of a high melting point metal such as Cr and molybdenum (Mo) are formed. At the same time, the storage capacitor electrode **54** is also formed. Then, an interlayer insulative film **95** having a structure in which a silicon oxide film (SiO<sub>2</sub> film) and a silicon nitride film (SiN film) are layered in that order is formed over the entire surface of the gate insulative film **92**. A contact hole is

formed to correspond to the drain **73D** and is filled with a metal such as aluminum (Al). The drain signal line **52** and a drain electrode **96** which forms a part of the drain signal line **52** are then formed. Over the film surface, a planarization insulative film **97** is provided for planarizing the surface, the film **97** being made of, for example, an organic resin.

[0062] Next, the formation process of the TFT **80** for driving the organic EL element **60** to emit light will be described. In FIG. 7B, structures formed of the same material as, and simultaneously with, the structures described above with reference to FIG. 7A are generally assigned the same reference numerals.

[0063] As shown in FIG. 7B, on the insulative substrate **90** as described above and made of quartz glass, non-alkali glass, or the like, an active layer **83** made of the polycrystalline silicon film is formed simultaneously with the active layer **73** of the TFT **70**. In the active layer **83**, a channel **83C** which is intrinsic or substantially intrinsic is provided below the gate electrode **81** and a source **83S** and a drain **83D** are provided at both sides of the channel **83C** by ion doping a p-type impurity, so that a p-type channel TFT is formed. Over the active layer **83**, the gate insulative film **92** and the gate electrode **81** made of a high melting point metal such as Cr and Mo are formed.

[0064] The gate electrode **81** is formed simultaneously with the gate electrode **71** in FIG. 7A, and is connected to the source **73S** of the TFT **70** as described above. Over the entire surface of the gate insulative film **92** and the gate electrode **81**, an interlayer insulative film **95** is formed in which a SiO<sub>2</sub> film and a SiN film are layered in that order. A contact hole is formed to correspond to the drain **83D** and is filled with a metal such as Al. At the same time, the driving power supply line **53** is formed. Furthermore, over the film surface, a planarization insulative film **97** is formed for planarizing the surface, the film **97** being made of, for example, an organic resin. A contact hole is formed in the planarization insulative film **97** to allow a connection to the source **83S** and a transparent electrode **61** which is to be connected to the source **83S** through the contact hole is formed on the planarization insulative film **97**. The transparent electrode **61** constitutes the anode of the organic EL element, and allows transmission, towards the side of the substrate **90**, of light emitted from the organic EL element **60** to be layered on top of the transparent electrode **61**. As the transparent electrode **61**, for example, an ITO (Indium Tin Oxide) which is an oxide of indium and tin is used.

[0065] The organic EL element **60** is constructed by forming and layering a light emitting element layer **66** and an Al cathode **67** in that order on top of the anode **61**. The light emitting element layer **66** further has a four-layer structure, each structure formed and layered above the anode **61** in order and made of a material, for example, as described below.

[0066] (1) Hole transport layer **62**: "NPB"

[0067] (2) Emissive layer **63**: following materials are used corresponding to each of different emission colors

[0068] Red—A host material "Alq<sub>3</sub>" doped with "DCJTb"

[0069] Green—A host material "Alq<sub>3</sub>" doped with "coumarin 6"

[0070] Blue—A host material “BAIq” doped with “perylene”

[0071] (3) Electron transport layer 64: “Alq<sub>3</sub>”

[0072] (4) Electron injection layer 65: lithium fluoride (LiF)

[0073] The abbreviations used above for describing the materials represent the following compounds.

[0074] “NPB”—N,N'-di(naphthalene-1-yl)-N,N'-diphenyl-benzidine

[0075] “Alq<sub>3</sub>”—Tris(8-hydroxyquinolino)aluminum

[0076] “DCJTB”—2-(1,1-dimethylethyl)-6-(2-(2,3,6,7-tetrahydro-1,1,7,7-tetramethyl-1H,5H-benzo[*ij*]quinoxalin-9-yl)ethenyl)-4H-pyran-4-ylidene)propanedinitrile

[0077] “Coumarin 6”—3-(2-benzothiazolyl)-7-(diethylamino)coumarin

[0078] “BAIq”—(1,1'-bisphenyl-4-olato)bis(2-methyl-8-quinolinylate-N1,08)aluminum

[0079] The hole transport layer 62, electron transport layer 64, electron injection layer 65, and cathode 67 are formed to be common for each of the organic EL elements 60 corresponding to a pixel as shown in FIG. 6. An island-like emissive layer 63 is formed corresponding to the anode 61. At the periphery of the anode 61, an insulative film (planarization insulative film) 68 made of an organic resin or the like is formed (outside the region shown by dotted lines in FIG. 6). This film is provided in order to prevent shortage of the cathode 67 and anode 60 caused by cracking of the emissive layer 63 due to the step created by the thickness of anode to 61.

[0080] When the pixel of the organic EL element 60 formed as described above is driven by the TFTs 70 and 80, holes injected from the anode 61 and the electrons injected from the cathode 67 are recombined within the emissive layer 63 and light is emitted.

[0081] When the above materials are used for each of the layers constituting the organic EL element 60, it is preferable to set the temperature that can be applied to the element layer 2 to 95° C. or less, in order to prevent degradation of characteristics of each layer.

[0082] By forming layers up to the cathode 67 on the substrate 90 as described above, a display substrate 3 as shown in FIG. 4 can be obtained. A sealing glass 4 and the obtained display substrate 3 are affixed through the above described method.

[0083] By affixing in this manner, in a method for manufacturing a display panel according to the first embodiment, the following advantages can be obtained.

[0084] (1) When the glass substrate 1 is sealed with the sealing glass 4, in consideration of the relationship between the viscosity of the adhesive 5 and the pressure applied to the affixing surface of the glass substrate 1 and the sealing glass 4, the temperature of the adhesive 5 is controlled so that the viscosity of the adhesive is at an appropriate value. Because of this, the shape of the adhesive 5 can be deformed quickly and smoothly in response to the pressure applied to the affixing surface.

[0085] (2) In this manner, the length of time required for achieving a target gap G of the affixing surfaces can be shortened.

[0086] (3) Moreover, because a more uniform gap G can be obtained at the affixing surface, the seal line width W is also stabilized, and, thus, a high quality seal can be provided for the display substrate 3.

[0087] (4) By controlling the temperature of nitrogen gas filling the chamber 20 to 35° C., it is possible to prevent degradation in the characteristics of the organic EL element formed on the display substrate 3.

[0088] (5) Moreover, by performing the sealing process in a nitrogen gas atmosphere having low moisture content, it is possible to minimize the moisture content remaining within the sealed space.

[0089] (Second Embodiment)

[0090] A method for manufacturing a display panel according to a second embodiment of the present invention will now be described referring to FIGS. 8 and 9. Similar as in the first embodiment, the second embodiment will be described using an example case in which the method is applied as a method for manufacturing a display panel having a display substrate constructed to include an organic EL element. In the following, the description focuses primarily on the structures differing from those of the first embodiment.

[0091] In the second embodiment, the device for applying a pressure to the supporting member 7 during the sealing process in the first embodiment further includes a function to monitor the applied pressure. This device for applying a pressure is shown in FIG. 8 as a pressure controller 25 which can arbitrarily control the applied pressure while monitoring the applied pressure.

[0092] In the second embodiment, the pressure applied to the affixing surfaces between the glass substrate 1 and the sealing glass 4 by the pressure controller 25 is changed over time to effect sealing.

[0093] FIG. 9 is a time chart showing an example pattern of pressure application by the pressure controller 25 for the supporting member 7. In the second embodiment, the temperature of nitrogen gas filling the chamber 20 is set at 35° C. which is identical to the set value of the temperature in the first embodiment.

[0094] In this second embodiment, the relative position between the glass substrate 1 and the sealing glass 4 is determined using the position controller 24 for the supporting member 7, and then a pressure is applied to the affixing surface between the glass substrate 1 and the sealing glass 4 according to the pressure application pattern shown in FIG. 9.

[0095] In this pressure application pattern, pressure is applied according to the following three conditions, (i), (ii), and (iii).

[0096] (i) Pressure changing periods (periods T<sub>1</sub>, T<sub>3</sub>, and T<sub>5</sub> in FIG. 9) in which the pressure is changed (increased) at a constant rate and pressure retaining periods (periods T<sub>2</sub>, T<sub>4</sub>, and T<sub>6</sub> in FIG. 9) in which the changed (increased) pressure is retained at a constant pressure are repeated so that the pressure and gap reach their respective target values.

[0097] (ii) The lengths of the pressure retaining periods  $T_2$ ,  $T_4$ , and  $T_6$  are set to equal to each other as indicated by the following equation.

$$T_2=T_4=T_6$$

[0098] (iii) The amount of change (amount of increase)  $\delta P_5$  of the pressure at the final pressure changing period  $T_5$  is set to be smaller than the respective amounts of change (amounts of increase)  $\delta P_1$  and  $\delta P_3$  of pressure at the previous pressure changing periods,  $T_1$  and  $T_3$ . In other words, the amounts of change  $\delta P_1$ ,  $\delta P_3$ , and  $\delta P_5$  satisfy the following relationships. In the example process shown in FIG. 9,  $\delta P_1$  and  $\delta P_3$  are equal to 0.2 kgw/cm<sup>2</sup> and  $\delta P_5$  is equal to 0.1 kgw/cm<sup>2</sup>.

$$\delta P_1 > \delta P_5$$

$$\delta P_3 > \delta P_5$$

[0099] In this manner, by applying a pressure of a predetermined pattern to the affixing surface between the glass substrate 1 and the sealing glass 4, the gap G reaches its target value at least at the pressure retaining period  $T_6$ , with the spacer (denoted by reference numeral 38 in FIG. 2) provided within the adhesive 5 acting as a stopper. The value of the gap G at this point is approximately 5  $\mu\text{m}$ . In order to inhibit the penetration of moisture at the sealing section, it is preferable that the gap G be set at 5  $\mu\text{m} \pm 1 \mu\text{m}$ , and, more preferably, 5  $\mu\text{m} \pm 0.3 \mu\text{m}$ . At the subsequent period,  $T_7$ , while the pressure is continued to be applied, the ultraviolet light source 23 is switched on at time  $t_6$  to start the irradiating of ultraviolet light onto the affixing surface through an infrared cut filter (not shown). The ultraviolet irradiation is continued for the duration of the period  $T_7$ , that is, until time  $t_7$ .

[0100] When the cross sectional shape of the adhesive 5 applied on the substrate is semicircular with a diameter of approximately 300  $\mu\text{m}$ , the size of the glass substrate 1 is 300 mm $\times$ 400 mm, and it is desired to obtain 9-96 display substrates 3 by cutting after the sealing process, the pressures applied to the affixing surface during the pressure retaining periods  $T_2$ ,  $T_4$ , and  $T_6$  respectively are, as shown in FIG. 9, 0.2 kgw/cm<sup>2</sup>, 0.4 kgw/cm<sup>2</sup>, and 0.5 kgw/cm<sup>2</sup>. The durations for each of the periods in the pressure application pattern are, from period  $T_1$  to period  $T_6$ , 5 seconds, 5 seconds, 10 seconds, 5 seconds, 5 seconds, and 5 seconds, respectively. In other words, the lengths of pressure retaining periods  $T_2$ ,  $T_4$ , and  $T_6$  are set at a ratio of 1:1:1. In order to obtain uniform gap G and uniform seal line width W (refer to FIG. 2) at the sealing section by the adhesive 5 to secure the sealing quality, the present inventors have found that it is desirable to set the above values within a range of  $\pm 20\%$  for the pressure and a range of  $\pm 50\%$  for the duration. The present inventors have also found that, for the ultraviolet irradiation period  $T_7$ , when the ultraviolet illumination is approximately 100 mW/cm<sup>2</sup>, it is desirable to set the length of period  $T_7$  to 60 seconds in order to obtain satisfactory curing of the adhesive 5.

[0101] Although in the above description, the pressure is represented in units of force of kilogram weight per square centimeter, that is, [kgw/cm<sup>2</sup>] for ease of description, the values for pressure can be converted into units of pascal, [Pa], which is the SI unit of pressure by multiplying by a constant 98066.5. For example, 0.2 kgw/cm<sup>2</sup> can be converted into 19.6 kPa, 0.4 kgw/cm<sup>2</sup> can be converted into 39.2 kPa, and 0.5 kgw/cm<sup>2</sup> can be converted into 49.0 kPa.

[0102] As described, in the second embodiment, because pressure is applied between the glass substrate 1 and the sealing glass 4 in stages and the adhesive 5 is then cured, a more uniform gap G and a more uniform seal line width W can be obtained at the sealing section between the glass substrate 1 and the sealing glass 4 by the adhesive 5.

[0103] For reference, the mechanism through which the uniform gap G and uniform seal line width W can be obtained at the sealing section will now be described referring to FIG. 10. FIG. 10 schematically shows the condition at the sealing section in which a pressure is applied to the adhesive 5 by the glass substrate 1 and the sealing glass 4. As shown in FIG. 10, for an adhesive 5 which has an approximately semicircular cross sectional shape immediately after application, initially, the area of the contact between the adhesive and the surface of the glass above the adhesive is small. Consequently, the adhesive 5 can be easily deformed even when a pressure of small magnitude is applied to the glass substrate 1 (refer to period  $T_1$  in FIG. 9). As the sealing section is pressed and the gap G is narrowed, however, the area of contact between the adhesive and the surface of the glass above the adhesive becomes larger, requiring a pressure of a larger magnitude (refer to periods  $T_3$  and  $T_5$  in FIG. 9). On the other hand, the highly viscous, elastic adhesive 5 deforms slowly to respond with a certain delay in time to the applied pressure. To this end, by retaining the increased pressure after the pressure to be applied is increased for a predetermined period of time (refer to periods  $T_2$  and  $T_4$  in FIG. 9), it is possible to secure time for the adhesive 5 to deform in response to the pressure change. Because the pressure is increased to the next stage after the retaining period, the shape of the adhesive 5 can change smoothly, and, consequently, the gap G and the seal line width W become uniform.

[0104] Normally, gas is present inside the sealing space. As the gap G is narrowed, the pressure increases and the gas attempts to escape outside. This attempt causes the sealing defect (A) as shown in FIG. 3. With the above method of the second embodiment, however, because it is possible to prevent rapid pressure increase through the pressure retaining periods (periods  $T_2$ ,  $T_4$ , and  $T_6$  in FIG. 9), the generation of sealing defects can be avoided. Therefore, generation of the sealing defect (A) or the like can be desirably avoided.

[0105] In FIG. 10, a configuration is shown in which the cross sectional shape of the adhesive 5 applied to the sealing glass 4 is approximately semi-circular immediately after the application, but, in general, the principle as described above is also applicable to other shapes such as, for example, a circular shape.

[0106] In addition, in order to simply secure the sealing quality, it is also possible to omit the pressure retaining period and slowly and continuously increase the pressure to be applied to reach a predetermined pressure. Such a configuration, however, requires a relatively very long time for manufacturing a display panel.

[0107] Also, in the second embodiment, it is possible to form an organic EL element layer having a structure as described in the first embodiment on the display substrate to construct an organic EL display panel.

[0108] As described, according to the method for manufacturing a display panel in the second embodiment, the

following advantages can be obtained in addition to those that can be obtained through the first embodiment.

[0109] (6) When the glass substrate **1** and the sealing glass **4** are affixed using an adhesive **5**, in addition to the adjustment of the viscosity of the adhesive **5** by the temperature control, the application pattern of the pressure for pressurizing the affixing surfaces for the glass substrate **1** and the sealing glass **4** is set as a repeated pattern of pressure changing periods and pressure retaining periods which follow the pressure changing periods. Because of this, it is possible to preferably secure the time for allowing the highly viscous adhesive **5** to deform in response to the applied pressure, which, in turn, allows for uniform gap *G* and uniform seal line width *W* at the sealing section in a shorter length of time.

[0110] (7) When applying a pressure to the affixing surfaces, it is possible to secure, in the pressure retaining period, sufficient time for the gas present in the sealing space to escape to the outside. Because of this, it is possible to prevent pressurized gas to remain within the sealed space.

[0111] (8) The sealing section having uniform gap *G* and uniform seal line width *W* obtained in this manner is even more reliable and, thus, it is possible to maintain, for a long period of time, predetermined characteristics as a display panel.

[0112] (Other Embodiments)

[0113] The above embodiments can be suitably modified and applied as follows.

[0114] In the above embodiments, nitrogen gas is used as the gas to fill inside the chamber **20**. However, the present invention is not limited to such a configuration. As long as the gas is an inert gas that has low moisture content and does not adversely affect the display substrate **3**, any gas, for example, a noble gas such as Ar, can be used in place of the nitrogen gas.

[0115] In the above embodiments, an example is shown in which a display substrate **3** onto which an organic EL element is formed is sealed. However, the present invention is not limited to such a configuration. For example, the method according to the present invention can be applied for sealing a display substrate onto which an inorganic EL element is formed as a light emitting element, a liquid crystal display substrate, or a plasma display substrate. The material of the substrate which forms the formation surface for the display element is not limited to glass as described in the above examples as a glass substrate **1**, and a suitable transparent resin substrate which transmits, for example, ultraviolet or other appropriate light may be used.

[0116] In the above embodiments, a sealing glass **4** is used as the sealing member for sealing the display substrate **3**. However, the present invention is not limited to such a configuration. For example, the display substrate **3** may be sealed using a metal casing (metal can). In this case, an adhesive suitable for the sealing member can be selected.

[0117] In the above embodiments, an epoxy resin is used as the ultraviolet curable adhesive for affixing the display substrate **3** and the sealing glass **4**. The present invention, however, is not limited to such a configuration, and, in addition to the epoxy resin, any ultraviolet curable resin which can be cured by irradiation of ultraviolet light and

which does not adversely affect the display substrate **3** can be used as the adhesive, including, but not limited to, a polyurethane resin, a polyester resin, and an acrylic resin.

[0118] In the above embodiments, an example structure of the element layer **2** to be formed on the display substrate **3** is described. However, the present invention is not limited to such a configuration, and the element layer can be formed in any construction.

[0119] In the example of the first embodiment, the temperature in which the sealing process is performed is set at 35° C. However, the present invention is not limited to that temperature. It is preferable that the temperature be set in a range in which the characteristics of the organic EL element formed on the display substrate **3** are not degraded and the viscosity of the adhesive **5** is at an appropriate level, for example, between 27° C. and 55° C. It is still more preferable that the temperature is set between 29° C. and 40° C. Moreover, in order to stably obtain uniform gap *G* and uniform seal line width *W* at the sealing section and to shorten the length of time to complete the sealing process, it is most preferable to set the temperature in the range between 32° C. and 38° C. When an organic EL element **60** is to be formed using the materials described in the first embodiment, it is preferable that the sealing temperature be set at approximately 95° C. or less in order to prevent degradation in the characteristics in each of the layers, although the specific set temperature depends on the material of the EL element.

[0120] Moreover, in the first embodiment as described above, the temperature during the sealing process is controlled to be at a constant value. However, the present invention is not limited to such a configuration. It is possible to actively vary the temperature so that the viscosity of the adhesive **5** used for the sealing process is suitable for the sealing process and to obtain advantages similar to those in the first embodiment. In this configuration, it is desirable that the temperature be controlled within the range in which the display element such as the EL element is not adversely affected.

[0121] In the example of the second embodiment described above, the temperature control for reducing the viscosity of the adhesive **5** is performed by controlling the temperature of nitrogen gas filled into the chamber **20**. However, the present invention is not limited to such a configuration. For example, as shown respectively in **FIGS. 11 and 12**, it is also possible to locally heat the adhesive **5** using one or more heaters or an infrared light. In this manner, it is possible to minimize the degradation in characteristics of the organic EL element caused by the heating of the organic EL element. In the example configuration shown in **FIG. 11**, one or more heaters **27** are embedded within a quartz glass **11a** below the sealing glass **4**, at positions corresponding to the positions on the sealing glass **4** where the adhesive **5** is applied. With this configuration, it is also possible to employ other heat sources such as, for example, a heat pipe, in place of the heater **27** embedded within the quartz glass **11a**. In the example shown in **FIG. 12**, the structure is configured so that infrared light irradiated from an infrared light source **28** is irradiated onto only the adhesive **5** through an infrared irradiation mask **29**. According to these methods for manufacturing, because in both configurations, the adhesive **5** is locally heated, it is possible

to shorten the length of time for manufacturing a display panel while maintaining the quality as an organic EL display device by minimizing rise in the temperature of the organic EL element. It is also possible that, in the device structure shown in FIG. 11 or FIG. 12, the pressure controller 25, instead of controlling the pressure change over time as in the second embodiment, simply applies a constant pressure which is set in advance to the glass substrate 1 via the supporting member 7. Also, the pressure controller 25 may be omitted as in the first embodiment.

[0122] In the examples illustrating the second embodiment as described above, the final pressure retaining period  $T_g$  is set as a time period until the gap G between the affixing surfaces of the glass substrate 1 and the sealing glass 4 reaches a predetermined value (target value). However, the present invention is not limited to these configurations. For example, it is possible to further provide an additional sensor or the like for monitoring the gap G and allow the curing process of the adhesive 5 to start based on a feedback value of the gap G from the sensor or the like. In this manner, it is possible to immediately start curing the adhesive 5 after the gap G has reached the target value, to thereby further shorten the length of time required for sealing. Moreover, the curing process for the adhesive 5 need not be started after the gap G has reached the target value, and it is also possible to set the timing so that the gap G reaches the target value during the curing process of the adhesive.

[0123] In the second embodiment as described above, an example pressure application pattern to the affixing surface between the glass substrate 1 and the sealing glass 4 has been described. The application patterns in the embodiment is not, however, limited to the example application pattern. For example, it is also possible to set the pressure retaining periods to be not equal and independently at different lengths, such as in a ratio of 1:2:3. Alternatively, it is also possible to set the pressure retaining periods such that a later period is longer in order to create deformation periods sufficient for even an adhesive whose viscosity is not as readily reduced by heating, and to thereby further improve precision. In addition, although the pressure changing period and the pressure retaining period are repeated for three cycles in the pressure application patterns in the above second embodiment, it is also possible to set the pressure application pattern to repeat different number of cycles, for example, two or four or more. Also, the amount of change (amount of increase) of pressure for the final pressure changing period need not be less than the amount of change (amount of increase) of pressure during the preceding pressure changing periods. Also, the rate of change of the pressure need not be constant. In other words, in at least one of the pressure changing periods, the rate of change of the pressure maybe actively set to be variable. Furthermore, the change in pressure for allowing the applied pressure to reach a target value need not be monotonically increasing, and, in some cases, a period in which the pressure is reduced may be present. In summary, any setting can be employed as long as uniform gap G and uniform seal line width W can be stably obtained between the glass substrate 1 and sealing glass 4 based on the application, in stages, of pressure for pressurizing the affixing surfaces between the glass substrate 1 and sealing glass 4.

[0124] In the description of the above second embodiment, a time period for allowing the adhesive 5 to follow the

applied pressure to deform is provided by providing pressure retaining periods. However, the present invention is not limited to such a configuration and it is possible, for example, to set the process so that the movement of the glass substrate 1 (and supporting member 7) is stopped while the adhesive 5 is being deformed.

What is claimed is:

1. A method for manufacturing a display device in which an element substrate and a sealing substrate are affixed via an adhesive therebetween, wherein a display element is formed on said element substrate, said sealing substrate is placed to oppose said element substrate at the side onto which said display element is formed, and said adhesive is provided at positions to surround the formation region of the element; said element substrate and said sealing substrate affixed to each other are pressed; and said adhesive is cured; and wherein

an ultraviolet curable resin is used as said adhesive; and

the temperature of said adhesive is controlled before said adhesive is cured by irradiation of ultraviolet light.

2. A method for manufacturing a display device according to claim 1, wherein

said adhesive is heated to a predetermined temperature before said element substrate and said sealing substrate affixed to each other via said adhesive therebetween are pressed.

3. A method for manufacturing a display device according to claim 1, wherein

said adhesive is heated to a predetermined temperature while said element substrate and said sealing substrate affixed to each other via said adhesive therebetween are pressed.

4. A method for manufacturing a display device according to claim 1, wherein

said adhesive is heated to a predetermined temperature in which the characteristics of the electroluminescence element formed as the display element are not degraded before said element substrate and said sealing substrate affixed to each other via said adhesive therebetween are pressed.

5. A method for manufacturing a display device according to claim 1, wherein

said adhesive is heated to a predetermined temperature in which the characteristics of the electroluminescence element formed as the display element are not degraded while said element substrate and said sealing substrate affixed to each other via said adhesive therebetween are pressed.

6. A method for manufacturing a display device according to claim 1, wherein

the temperature of said adhesive is controlled based on application conditions of the pressure for pressing said element substrate and said sealing substrate.

7. A method for manufacturing a display device according to claim 6, wherein

the temperature of said adhesive is set at a temperature in which the characteristics of the electroluminescence element formed as the display element are not degraded.

**8.** A method for manufacturing a display device according to claim 1, wherein

the pressure for pressing said element substrate and said sealing substrate is changed over time until a target gap is achieved between said element substrate and sealing substrate affixed to each other.

**9.** A method for manufacturing a display device according to claim 8, wherein

said pressure for pressing said element substrate and said sealing substrate is changed over time by repeating a pressure changing period in which the pressure is changed and a pressure retaining period in which a constant pressure is maintained.

**10.** A method for manufacturing a display device according to claim 9, wherein

a plurality of said pressure changing periods and a plurality of said pressure retaining periods are repeated; and

the duration of each of said plurality of pressure retaining periods is independently set to an arbitrary length.

**11.** A method for manufacturing a display device according to claim 9, wherein

a plurality of said pressure changing periods and a plurality of said pressure retaining periods are repeated; and

the amount of change in pressure for each of said plurality of pressure changing periods is independently set to an arbitrary value.

**12.** A method for manufacturing a display device according to claim 11, wherein

said amount of change in pressure for a final pressure changing period among said plurality of pressure changing periods is smaller than the amount of change in pressure for any previous pressure changing period.

**13.** A method for manufacturing a display device according to claim 8, wherein

the rate of change of pressure in at least one of said plurality of pressure changing periods differs from a rate of change of pressure in the other periods.

**14.** A method for manufacturing a display device according to claim 9, wherein

said pressure is changed over time through 3 repetitions of pressure changing periods in which pressure is changed and pressure retaining periods in which a constant pressure is maintained.

**15.** A method for manufacturing a display device according to claim 1, wherein

said adhesive is a cation polymerizing, ultraviolet curable epoxy resin.

\* \* \* \* \*

专利名称(译)	显示装置的制造方法		
公开(公告)号	<a href="#">US20030011737A1</a>	公开(公告)日	2003-01-16
申请号	US10/183252	申请日	2002-06-27
[标]申请(专利权)人(译)	松冈秀树		
申请(专利权)人(译)	松冈秀树		
当前申请(专利权)人(译)	SANYO ELECTRIC CO. , LTD.		
[标]发明人	MATSUOKA HIDEKI		
发明人	MATSUOKA, HIDEKI		
IPC分类号	H05B33/10 G02F1/1333 G02F1/1339 G09F9/00 G09F9/30 H01L27/32 H01L51/50 H01L51/52		
CPC分类号	G02F1/1339 H01L27/32 H01L51/5237 H01L27/3244 H01L51/5246		
优先权	2001198921 2001-06-29 JP		
其他公开文献	US7106409		
外部链接	<a href="#">Espacenet</a> <a href="#">USPTO</a>		

摘要(译)

其上形成有机电致发光 ( EL ) 元件等的显示面板的玻璃基板通过粘贴玻璃基板和其上已施加有粘合剂的密封构件 ( 例如密封玻璃 ) 来密封。在此过程中, 通过例如控制氮气的温度以通过温度调节装置填充腔室来控制粘合剂的温度, 从而调节粘合剂的粘度。以这种方式, 可以实现密封构件和粘合剂对显示基板的快速且精确的密封。

